

MotorGuide® REPAIR PARTS

Model: **POWERplus**
ET45V

SPECIFICATIONS:

Year of Intro 2000
 Thrust 45LBS
 Volts 12VDC
 Amp Draw 0 to 48 amps
 Mount 09 Transom
 Speeds Variable

PARTS ORDERING & TECH ASSISTANCE

MotorGuide Consumer Relations
 Phone 918-831-6989
 Fax 800-982-8093

Returned Goods must be accompanied with a Returned Goods Authorization. Contact MotorGuide Consumer Relations to obtain RGA.

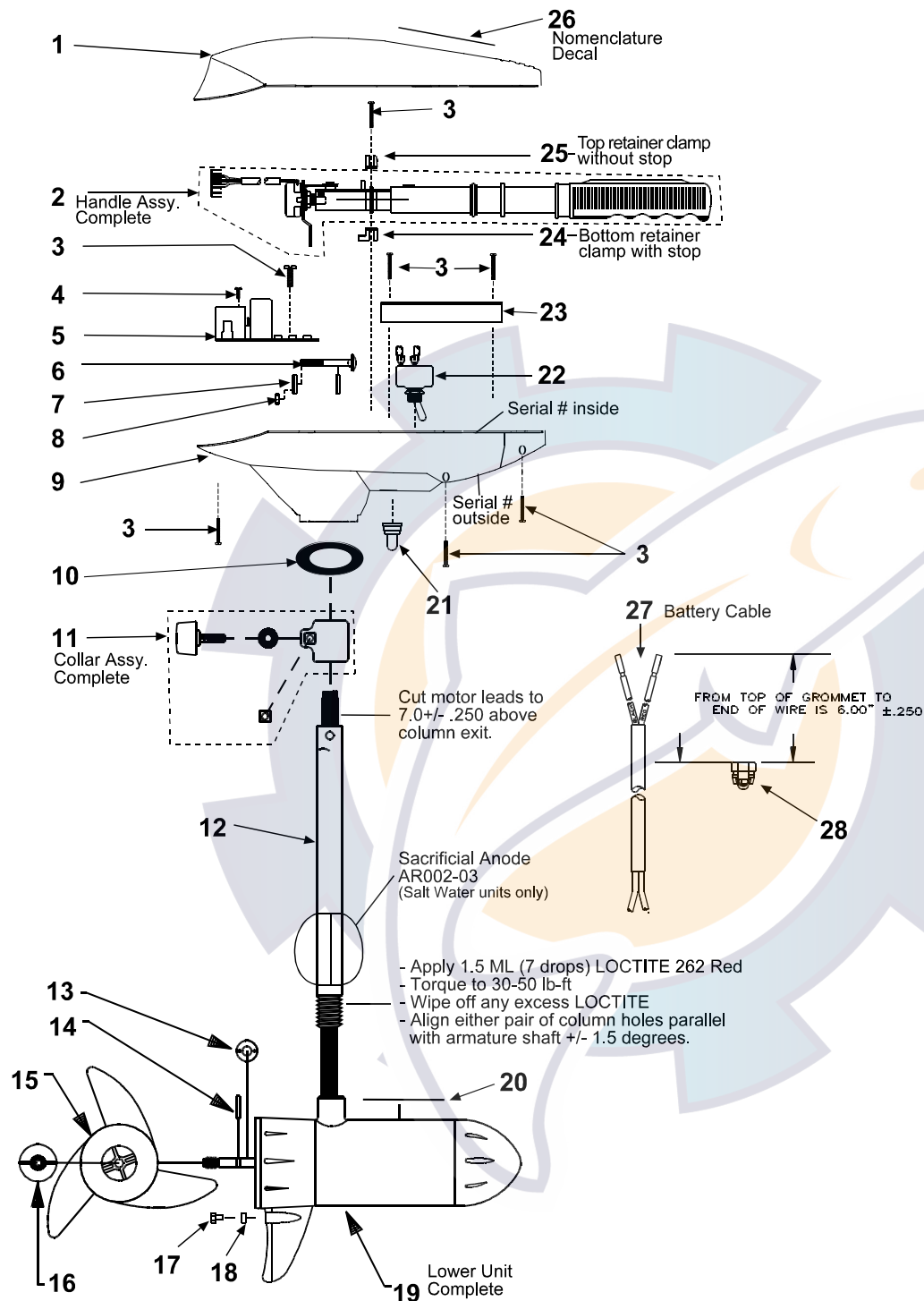

KEY	DESCRIPTION	PART #	KEY	DESCRIPTION	PART #	KEY	DESCRIPTION	PART #
1	TOP HOUSING COVER BLACK	ET053-17	12	COLUMN 36"	TT049-05	20	LOWER UNIT DECAL	ET060-08
2	HANDLE ASY	ET372-06		COLUMN 42"	TT049-06	21	SWITCH BOOT	FP177-01
3	#8 X 5/8 SCREW	AT141-01		COLUMN 50"	FR049-13	22	TOGGLE SWITCH	FP153-07
4	#4 SELF TAPPING SCREW	XT141-02	13	MONOFILAMENT WASHER	AR175-01	23	CABLE PLATE	AT155-06
5	BOARD FOR/REV	AT157-01	14	PROP DRIVE PIN	BR102-01	24	BOTTOM RETAINER CLAMP	AR036-02
6	BOLT	TT134-02	15	PROP/3 BLADE	AF124-12	25	UPPER RETAINER CLAMP	AR036-04
7	CURVED WASHER	TT171-08		PROP/2 BLADE	AF124-07	26	NOMENCLATURE DECAL	TT056-12
8	NYLON LOCK NUT	XT098-02	16	PROP NUT	AR099-01	27	BATTERY CABLE	XT328-06
9	T/H BASE BLACK	AT004-11	17	ANODE BOLT (Saltwater models only)	DK133-01	28	GROMMET	GR019-01
10	COLUMN SEAL	AT079-01	18	ANODE (Saltwater models only)	AR002-02			
11	DEPTH ADJUSTMENT COLLAR	AR158-01	19	MOTOR	CM397-04			

LOWER UNIT BREAKDOWN

Model:
ET45V

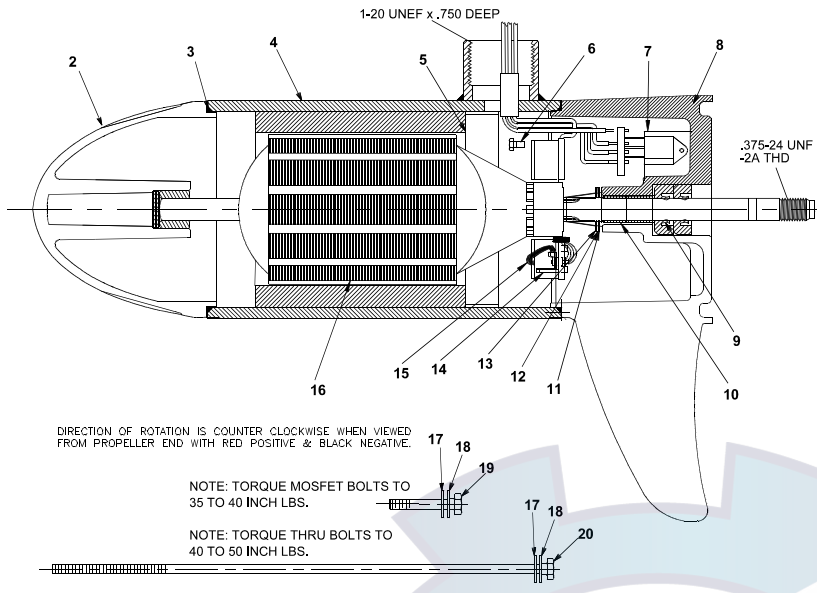

DIRECTION OF ROTATION IS COUNTER CLOCKWISE WHEN VIEWED FROM PROPELLER END WITH RED POSITIVE & BLACK NEGATIVE.

NOTE: TORQUE MOSFET BOLTS TO 35 TO 40 INCH LBS.

NOTE: TORQUE THRU BOLTS TO 40 TO 50 INCH LBS.

KEY	QTY	DESCRIPTION	PART NO.
1	X	MOTOR	CM397-04
2	1	NOSE CAP	XF3212-01
3	2	O RING SEAL	MR217-01
4	1	HOUSING ASY	JF3210-01
5	1	RETAINER	JF233-01
6	2	BRUSH CARD SCREW	MR228-01
7	1	DURA AMP MODULE	JF096-09
8	1	COMM CAP	UF3205-08
9	2	SHAFT SEAL	MR223-01
10	1	BEARING	MR206-01
11	1	NYLATRON WASHER	MR226-01
12	1	WASHER	MR227-01
13	1	E RING	MR219-02
14	2	BRUSH SPRINGS	MR214-02
15	1	BRUSH ASY PLUG IN	JF3202-02
16	1	ARMATURE	UF3205-08
17	4	STATIC SEAL	MR222-01
18	4	THRU BOLT WASHER	MR216-02
19	2	DURA AMP SCREW	MR229-01
20	2	THRU BOLT	MR218-03
21	1	BRUSH CARD	UF3201-06

WIRING

